



# TECHNICAL DATA SHEET

## MODEL UC090FE

### UNDERCOUNTER FREEZER



Consistent freezing performance to safeguard valuable laboratory samples.

<h1>0.9</h1> <h2>°C</h2>	<h1>72</h1> <h2>Minutes</h2>	<h1>17</h1> <h2>Minutes</h2>
--------------------------	------------------------------	------------------------------

**Temp. Uniformity**

**Pull-Down to -30°C**

**1-Minute Door Opening**

*Test Under Energy Star standard (Lab Grade Freezer)*

## SPECIFICATIONS

### → -15 to -30°C Freezer

Model	UC090FE
Capacity	90L (3.18 cuft)
Internal Chamber Size (W X D X H)	440 X 465 X 480mm (17.3 X 18.3 X 18.9 in)
External Size (W X D X H)	600 X 624 X 812mm (23.6 X 24.6 X 32 in)
Package Size (W X D X H)	662 X 682 X 892mm (26.1 X 26.9 X 35.1 in)
Product Weight (Kgs/Lbs)	52kg (114.64 lbs)
Shipping Weight (Kgs/Lbs)	59kg (130.07 lbs)

### → Performance

Temperature Range	-15 to -30°C
Ambient Temperature	16-32°C
Climate Class	Indoor Use Only
Controller	Microprocessor
Display	Digital Display
Noise	44.1 dB(A)

### → Refrigeration

Compressor	Single
Cooling Method	Direct Cooling
Defrost Mode	Manual
Refrigerant	R290
Insulation Thickness (mm)	80mm

## → Construction

External Material	Powder Coated Steel
Inner Material	Sprayed Aluminum Steel
Shelves	2 + 1 (basket)
Access Test Port	1 pc. 025mm
Casters	2 (2 Leveling Feet)
Interface	Remote Alarm Contact

## → Alarms

Temperature	High/Low Temperature, High Ambient Temperature
Electrical	Power Failure, Low Battery, Data Logger Failure
System	Sensor Error, Door Ajar, Data Communication Failure

## → Electrical

220-240V/50Hz
1.7A

## → Certifications

UL (2024-10-24 - E509170)

Manufacturing Facility certified to ISO 9001:2015 and ISO 13485:2016 quality management system standards  
Medical device classification: Class II (U.S), Class IIa (EU MDR)

## DIMENSIONS

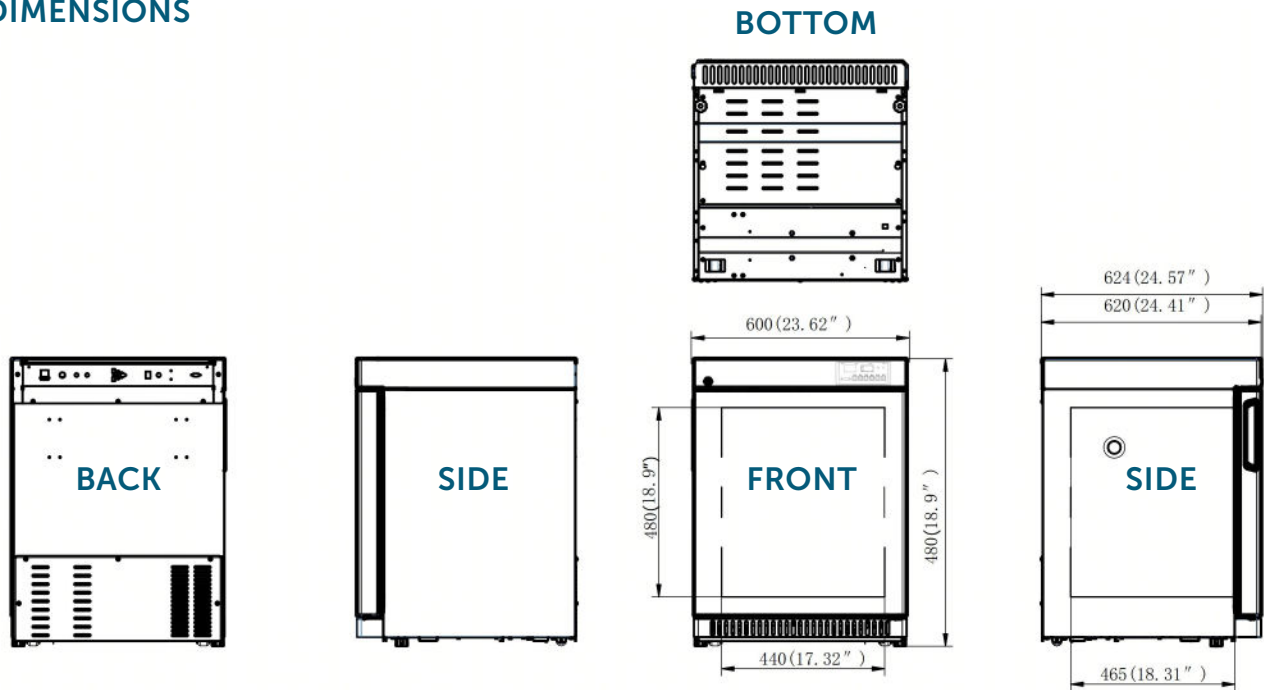

Stirling Ultracold 6000 Poston Road, Athens, Ohio 45701, USA  
T 740.274.7900 / 1.855.274.7900 | F 740.274.7901 | [www.stirlingultracold.com](http://www.stirlingultracold.com)

©2024 Stirling Ultracold, Global Cooling, Inc. All Rights Reserved.

Global Cooling technology is manufactured under U.S. and International patents.  
Stirling Ultracold is a trademark of Global Cooling, Inc. Specifications subject to change without notice. Refer to [www.stirlingultracold.com](http://www.stirlingultracold.com) for the latest specifications.



**REDEFINING COLD**